

DADANT STYLE FRAME

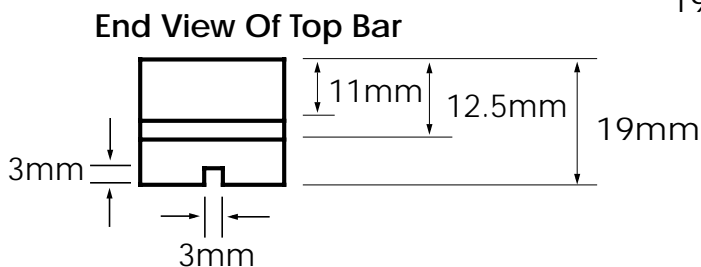

As with the Hive Boxes, I use Radiata Pine for the construction of frames, 19mm thick boards for the Top and Bottom bars and 35mm thick boards for the sides. It is important to select timber without knots to ensure the frames are not weakened which could cause problems when extracting.

Making frames is a very time consuming and fiddly process and I recommend it only as an exercise in fully understanding the function of items used in Beekeeping and so you can say you made them yourself. Also unless you have access to very cheap timber it is hardly cost effective to make your own frames.

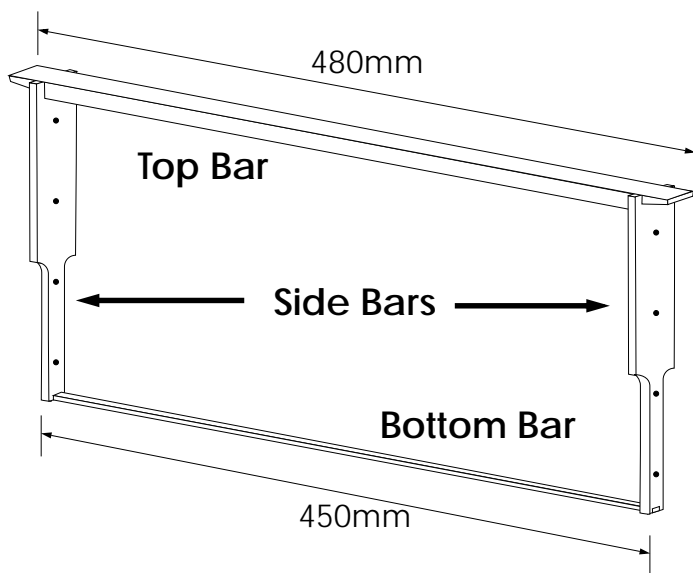

At the time of writing this, in Canberra, the retail cost of Radiata Pine, to make one frame, was 99c. (Not allowing for wastage) The retail price to buy one frame was \$1.10 with discounting available for buying frames in quantity i.e. in lots of 100. So making your own would save you 11c a frame, not allowing for wastage.

If time is important to you, you can also buy frames assembled, assembled and wired or assembled, wired and with foundation installed. Each increasingly more expensive.

